

DRINKS | Drink Cabinets

DRINK COOLER ► UPRIGHT COOLERS



RCF 130



**CUSTOMIZATION
AVAILABLE**
PERSONALIZZAZIONE
DISPONIBILE



50 mm



K2

-1°C
+6°C



C

ENERGY
CLASS

CC1

+25°C
60RH



GAS

R600a



LED

DETAILS

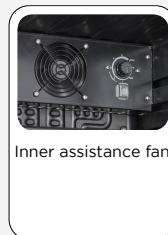

Inner assistance fan

GENERAL FEATURES

130 Lt. Upright drink cooler	•
External in black coated plate, black aluminium internally	•
Roll-bond evaporator system with fan assisted cooling	•
Manual Defrost	•
Foaming Agent Cyclopentane (50mm per side)	•
Removable Gasket	•
Independent switch for internal light	•
Double layer safety tempered glass (Curved)	•
Door: Self closing and reversible door fitted as standard	•
Adjustable chromed shelf (5 Pcs) and chromed basket (1 Pcs)	•
N.4 Adjustable feet	•
Customization available	•
Energy efficiency class: C	•

TECHNICAL SPECIFICATIONS

Capacity	130 L
Temperature	K2 (-1°C-+6°C)
Consumption	0.9 kWh/24h
Rated Power	110 W
Noise level	39 dB(A)
Net Weight	30 Kg
Gross Weight	34 Kg
External Dimensions (WxDxH mm)	540x548x845
Internal Dimensions (WxDxH mm)	420x448x723
Packaging dimensions (WxDxH mm)	580x590x870
Loading quantities 20'/40'/40'HQ	N/A/238/N/A

CERTIFICATION

CE  RoHS

PRODUCT DIMENSIONS

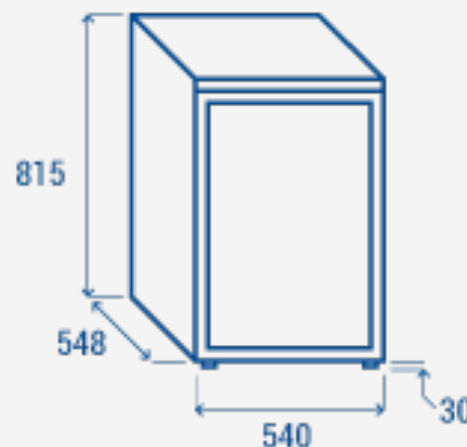

COOL HEAD EUROPE
We make the world a cooler place



www.coolheadeurope.com